

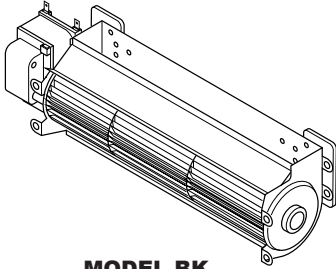

FMI PRODUCTS, LLC

**BK AND BKT BLOWER ACCESSORY
INSTALLATION INSTRUCTIONS**



**MODEL BK
MANUALLY CONTROLLED
BLOWER**

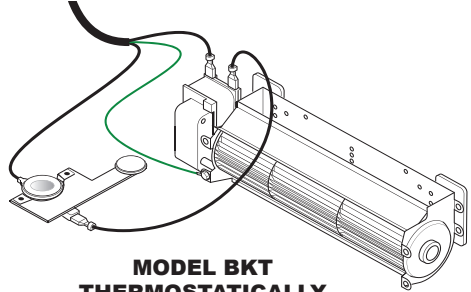

**MODEL BKT
THERMOSTATICALLY
CONTROLLED BLOWER**

⚠ WARNING: ELECTRICAL GROUNDING INSTRUCTIONS This appliance is equipped with a three-prong (grounding) plug for your protection against shock hazard and should be plugged directly into a properly grounded three-prong receptacle.

(Check your appliance owner's manual for specific applications and additional instructions.)
Parts included with this kit.

PART NO.	DESCRIPTION			QTY
		BK	BKT	
126114-01	Blower assembly with speed control and 6 foot cord	•	•	1
104901-01	Wire assembly		•	1
103650-01	Control Knob		•	1
103651-01	Lock Nut		•	1
11164	#8- 1/2" Phillips Head Screw		•	2
126085-01	Thermodisc Magnetic Bracket Assembly		•	1
109892-01	Speed Control Bracket (Stamped Face Models)	•	•	1
109892-02	Speed Control Bracket (Panel Louver Models)	•	•	1
108998 01	Installation Instructions		•	1

Tools required

- Pliers
- Phillips Screwdriver
- Flat Blade Screwdriver

If any of these pieces are missing or damaged, or if the installation instructions for your fire-place or stove are not included in this manual, contact the dealer where you purchased this kit or FMI PRODUCTS, LLC at 1-866-328-4537 for referral information.

Save this manual for future reference

The BK and BKT blowers utilize the same rotary squirrel cage type blower with magnetic attachment and variable speed control. The BKT also includes an additional thermostatically controlled feature for use on some direct-vent models only.

The BK blower can be installed in wood burning, B-vent and vent-free model fireplaces. Both the BK and BKT blowers can be installed in direct-vent model fireplaces. Blowers are installed by accessing the blower compartment through the lower louver panel or, on some models, through the control access cover under the front refractory panel (see Figure 1). The lower front louver panel can be removed easily, see *removing louver panel*, page 3 for instructions.

⚠ WARNING: If there is a duplex electrical outlet installed in the right side of the bottom of the fireplace base area (see Figure 2), be sure that the electrical power to the outlet is turned off before proceeding with blower installation. Failure to do this may result in serious injury.

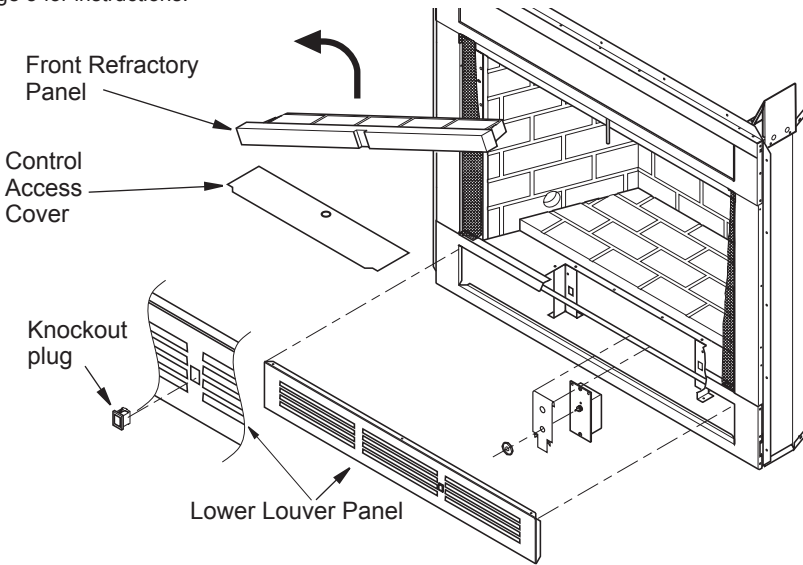

Figure 1: Accessing Blower Compartment (Controls Not Shown for Clarity) B-vent, Wood and Vent-Free Models

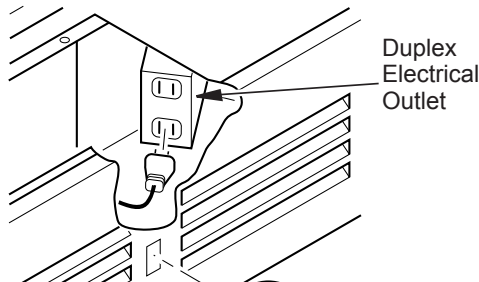

Figure 2: Accessing Duplex Electrical Outlet installed in Bottom Right Side of Firebox

REMOVING LOUVER PANEL

WOOD, B-VENT AND VENT-FREE MODELS

For models other than direct-vent, remove panel or stamped face louver by snapping out the front with a flat blade screwdriver (see Figure 1, page 2). Use caution not to scratch any surfaces. These panels can also be removed by inserting fingertips between slots and gently pulling out. **DO NOT FORCE**. The panels are actually held in place by means of a retention dimple embossed on the edge of the panel. To reinstall, place louver into cavity and push gently.

DIRECT-VENT MODELS

There are two different types of direct vent louvers: spring latch and bullet-style clip.

Spring Latch: Remove louver with spring latches by simultaneously pulling both top spring latches toward the center of the appliance until they are disengaged from the latching holes. Repeat for bottom spring latches and pull louver outward (see Figure 3). To reinstall, simple reverse procedure.

Bullet-Style Clip: Remove louver with bullet-style clips by using a flat blade screwdriver and snapping louver forward. Use caution not to scratch any surfaces. These panels can also be removed by inserting fingers between slots on louver and gently pulling out. **DO NOT FORCE** (see Figure 4). To reinstall, align bullet-style clips with locating holes on inside of firebox and push gently.

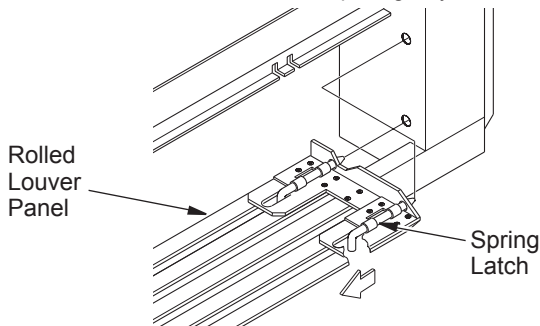

Figure 3: Removing Louver Panel with Spring Latches (Direct-Vent Models)

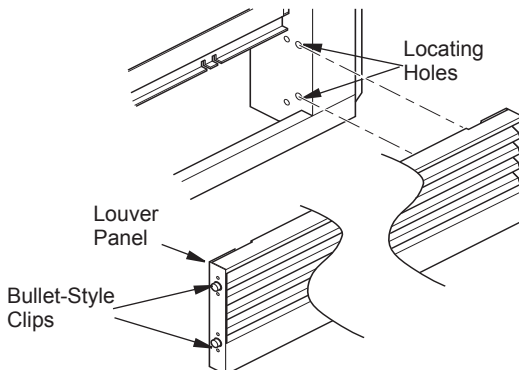

Figure 4: Removing Louver Panel with Bullet-Style Clips (Direct-Vent Models)

MODEL BK WIRE ASSEMBLY

Note: Speed control switches can not be installed into filigree panels. Installing a wall switch or thermostat in the wall outside of fireplace will eliminate removing bottom louver to adjust operation of blower.

1. Attach the power cord to the blower motor by firmly pushing the two female terminals at the end of the power cord onto the two spade terminals on the blower motor (see Figure 5).
2. Attach green ground wire from power cord to blower housing using screw provided (see Figure 5) Tighten screws securely with a Phillips screwdriver.
3. Place the blower against the lower rear wall of the firebox outer wrapper with the exhaust port directed upward. Depending on your model, you may have to carefully route the blower assembly past the controls and brackets, and position the blower inside the back opening. The blower will be held in position against the back wall by the magnets incorporated onto the blower housing (see Figure 5).
4. Be certain that all wire terminals are securely attached to terminals on blower motor and that the screw retaining the green ground wire is tight.

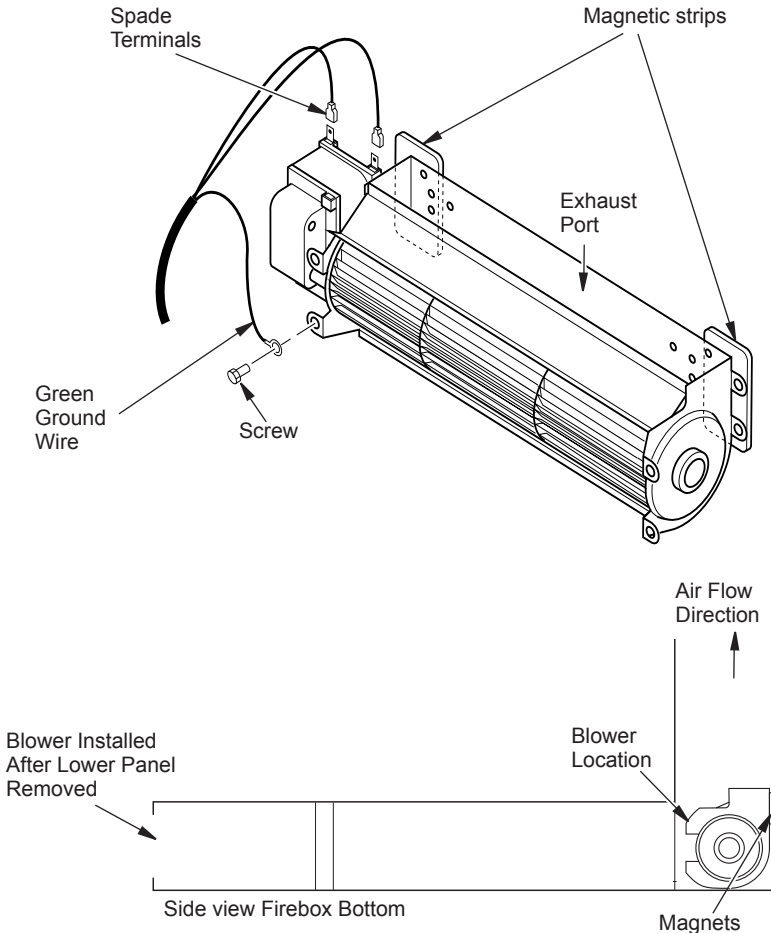

Figure 5: Blower Model BK

MODEL BKT WIRE ASSEMBLY

Note: The BKT blower is for application into direct-vent models only. When installing the BKT thermostatically-controlled blower, you must first secure the wiring connections from the thermal switch to the blower (if it has not already been factory installed).

1. Attach green ground wire from power cord to blower housing using screw provided (see Figure 6) Tighten screws securely with a Phillips screwdriver.
2. Connect wire harness and power cord terminals. Connect the jumper wire to the blower motor terminal to the terminal of the thermal switch. Connect one wire of the thermal switch and one wire to the other remaining blower motor terminal.

Note: The power cord outer insulation sleeve may have to be stripped slightly to allow enough wire length to reach and make all connections. DO NOT trim excessive length away. Just enable enough to make all connections securely.

3. Place the blower against the lower rear wall of the firebox outer wrapper with the exhaust port directed upward. Attach Thermal disc magnetic bracket to the bottom of the firebox sub-floor. The thermodisc must be oriented near the fireplace bottom as shown in Figure 6, in order to sense temperature and properly operate. The blower will be held in position against the back wall by the magnets incorporated onto the blower housing (see Figure 6).
4. Be certain that all wire terminals are securely attached to terminals on blower motor and that the screw retaining the green ground wire is tight.
5. To mount speed controls, see *Mounting Speed Control for All Direct Vent Models*, *Mounting Speed Control for All Models with Panel Louvers* (page 6, column 1) or *Mounting Speed Control for All Models with Stamped Face Louvers* (page 6, column 2), depending on your model.

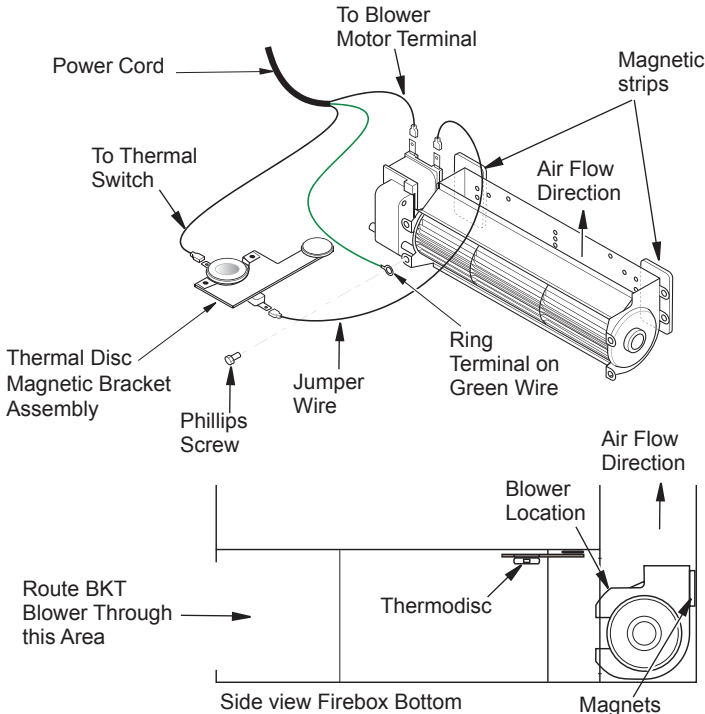

Figure 6: Blower Model BKT

MOUNTING SPEED CONTROL

DIRECT-VENT MODELS

Mount the speed control box by placing the plastic control shaft forward through the mounting opening on the pre-installed bracket (see Figure 7).

While supporting the speed control in the vertical position, secure the control shaft by pushing and turning the lock nut with pliers until it is tight against the mounting bracket. Place control knob provided on the control shaft (see Figure 7).

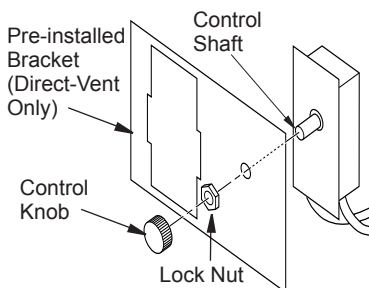

Figure 7: Attaching Speed Control to Direct-Vent Firebox

MODELS WITH STAMPED PANEL LOUVERS

Wood, B-Vent, and Vent-Free models

1. Position speed control bracket by inserting flange of bracket between hearth pan and upper flange of louver opening, then seat bottom end of bracket onto lower flange of louver opening (see Figure 8).
2. Mount speed control box by placing plastic control shaft through bottom hole on speed control bracket. Top screw head on control box will fit inside top hole on bracket (see Figure 8). Secure speed control to bracket with lock nut by pushing and turning lock nut with pliers clockwise until it is tight against bracket.
3. Remove knockout plug from louver panel by depressing top and bottom retaining clips (see figure 1, page 2).
4. Place louver panel, louvers pointing up, back into framed opening. Align control shaft with rectangular opening by sliding control bracket along flange (see Figure 8).
5. Fully seat louver panel into frame opening by gently pressing along ends until all dimpled retainers have snapped in place.

6. Place control knob, provided, onto control shaft (see Figure 8).

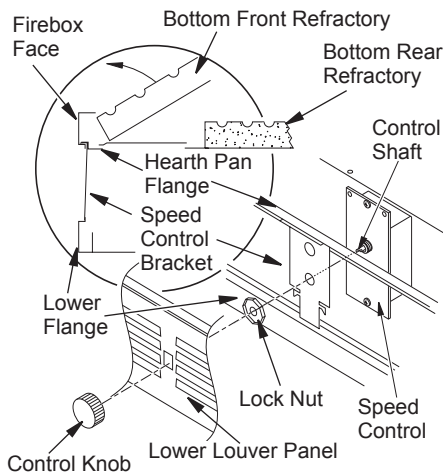

Figure 8: Attaching Speed Control to Firebox with Panel Louvers Using Speed Control Bracket 109892-02

MODELS WITH STAMPED FACE LOUVERS (B36, VB36 WOOD BURNING UNITS)

1. Using pliers, bend two retaining tabs on speed control bracket 90 degrees to front of bracket (see Figure 9, page 7).
2. Mount speed control box by placing plastic control shaft through bottom hole on speed control bracket. Top screw head on control box will fit inside top hole on bracket (see Figure 9, page 7). Secure speed control to bracket with lock nut by pushing and turning lock nut with pliers clockwise until it is tight against bracket.
3. Remove knockout plug from louver panel by depressing top and bottom retaining clips (see Figure 1, page 2).
4. Position speed control assembly over flange on hearth pan by sliding bracket up between the face and flange, then down until the control shaft is aligned with the opening in the louver panel (see Figure 9, page 7).
5. Lock two retaining tabs onto lower louver by pressing down on bracket assembly while sliding control knob through rectangular opening on louver and onto the control shaft (see Figure 9, page 7).

MOUNTING SPEED CONTROL *Continued*

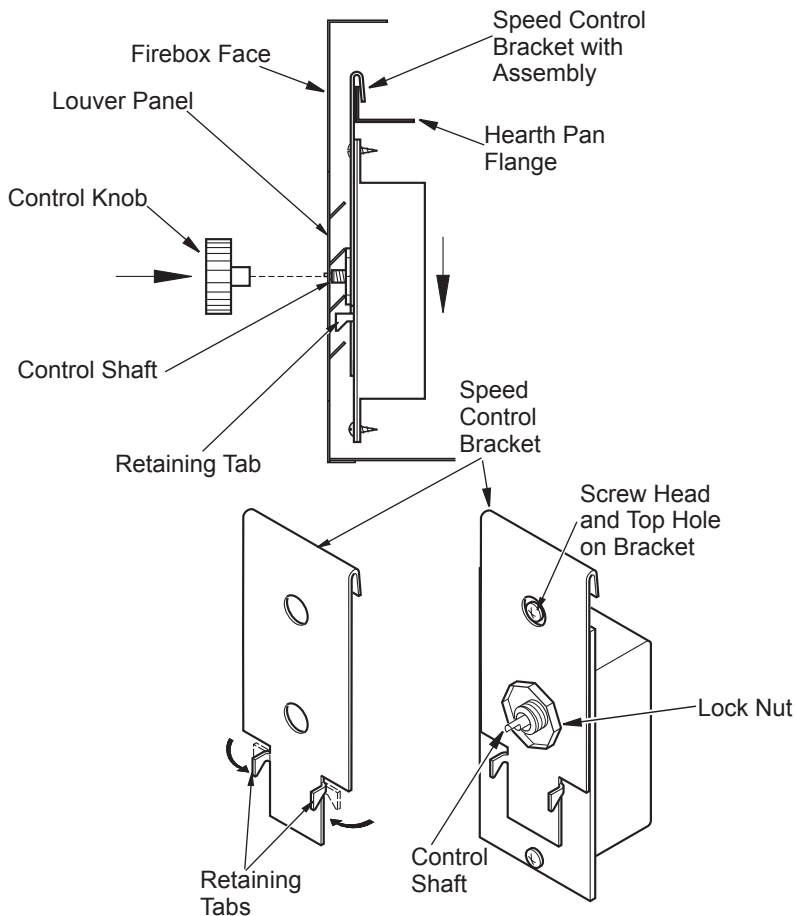

Figure 9: Attaching Speed Control to Firebox with Stamp Faced Louvers (B36 and VB36 Models) Using Speed Control Bracket 109892-01

CONNECTING POWER AND OPERATING BLOWER

1. Check to make sure that the power cord is completely clear of the blower wheel and that there are no other foreign objects in blower wheel. Also double check all wire leads and make sure wire routing is not pinched or in a precarious position. Correct accordingly.
2. Turn on power to duplex outlet if previously turn off per the warning on page 2.
3. Plug in blower power cord to duplex outlet (see Figure 2, page 2).
4. BK Model: Turn blower on and check for operation. Turn blower off by turning knob fully counterclockwise before continuing.

CAUTION: Never touch the blower wheel while in operation.

CONNECTING POWER AND OPERATING BLOWER

Continued

5. BKT Model: The blower will only run when the speed control knob is in the ON position and the Thermal switch senses temperature after the fireplace begins to heat up. The blower speed can be adjusted by rotating the control knob. To turn off, turn knob fully counterclockwise until it clicks off. If the blower is ON and has been running with the fireplace operating, the blower will continue to run for a short time after the fireplace has been turn off. As the thermal switch cools down, the blower shuts down automatically.
6. Peel off the backing paper and stick the supplied wiring diagram decal on the firebox bottom approximately 12" in front of the blower (see Figure 10).
7. Replace all panels and/or brick bottom if previously removed.

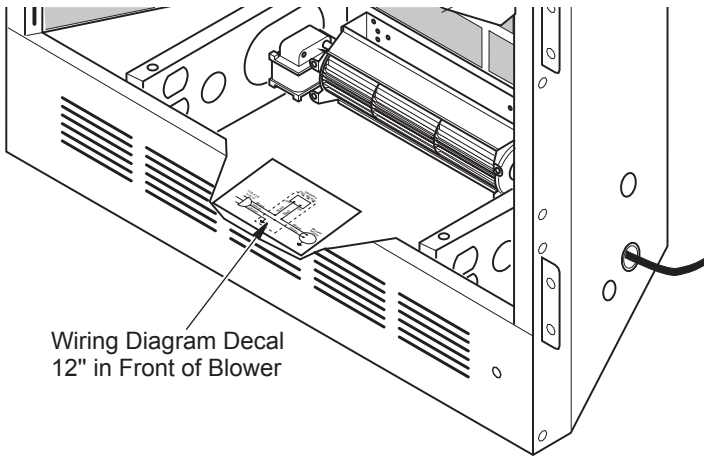

Figure 10: Location of Wiring Diagram Decal (Model May Vary From Illustration)

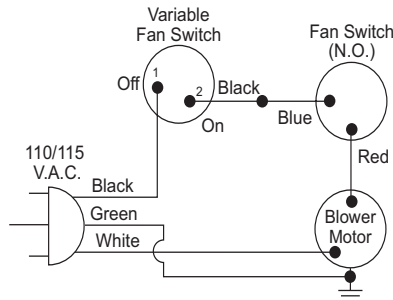

Figure 11: Wiring Diagram (BKT Model Only)

FMI PRODUCTS, LLC
 2701 S. Harbor Blvd.
 Santa Ana, CA 92704
 1-866-328-4537
www.fmiproducts.com

108998-01
 Rev. H
 11/11